

This Instrument Prepared by:  
The Development Corporation of Knox County  
17 Market Sq., #201  
Knoxville, TN 37902

*Sherry Witt*  
Register of Deeds  
Knox County

Hardin Business Park  
Amended and Restated Design Standards  
and Restrictive Covenants

October 9, 2014

The Development Corporation of Knox County  
17 Market Square, #201  
Knoxville, TN 38902  
(865) 546-5887



Knox County Page: 1 of 72  
REC'D FOR REC 12/19/2014 2:22:30PM  
RECORD FEE: \$362.00  
M. TAX: \$0.00 T. TAX: \$0.00

**201412190033884**

# Hardin Business Park

## Amended and Restated Design Standards and Restrictive Covenants

---

Design Standards and Restrictive Covenants.....	5
HOW TO USE THESE COVENANTS.....	5
Step One – Choosing Hardin Business Park.....	5
Step Two – Site Selection and Design.....	5
Step Three – Review.....	5
Step Four – Permit Release.....	6
DECLARATION OF DESIGN STANDARDS AND RESTRICTIVE COVENANTS...	6
SECTION 1: INTRODUCTION.....	7
A. – Purpose of these Standards.....	7
B. – Permitted uses.....	8
C. – Specific uses Not Permitted.....	8
D. – Submittal Requirements.....	9
E. – Definitions.....	10
F. – Re-Purchase Provisions.....	13
SECTION 2: DESIGN AND PLAN SUBMISSION - REVIEW PROCESS.....	13
A. – Design Review Board.....	13
B. – Requirements for the Granting of a Wavier or Special Exception.....	15
C. – Approval of Plans.....	16
(1) General.....	16
(2) Issuance of Building and Related Permits.....	16
(3) Commencement of Construction.....	17
(4) Unapproved Construction or Improvements.....	17
SECTION 3: SITE AND STRUCTURE COVENANTS.....	17
Site Design.....	17
General.....	17
Clearing and Grading.....	19
Stream Buffer.....	20
Circulation.....	20
General.....	20
Pedestrian Improvements.....	21
Parking.....	21
Loading and Unloading Areas.....	23
Vehicular Entrances.....	24
Building Setbacks and Lot Coverage.....	24
General.....	24
Building Setbacks / Coverage.....	25
Architecture.....	26
General.....	26



# Hardin Business Park

## Amended and Restated Design Standards and Restrictive Covenants

---

Building Design .....	27
Landscaping .....	31
General .....	31
1. Plant Material .....	32
2. Buildings .....	32
3. Parking Areas .....	33
4. Service Areas .....	34
5. Open Spaces .....	34
6. Maintenance/Survival .....	35
Lighting .....	35
General .....	35
Guidelines .....	35
Power, Telephone, Utilities, and Water/Sewer .....	36
Signage .....	37
Guidelines .....	38
Additional Standards .....	41
Commercial Parcels .....	41
Noise .....	42
Pollutants .....	42
Site Drainage and Storm Water Retention Landscaping .....	43
Maintenance .....	43
Grievances and Conflicts .....	43
SECTION 4: GRANT OF EASEMENTS; COVENANT FOR MAINTENANCE ASSESSMENTS .....	44
A. – Grant of Easements .....	44
B. – Creation of the Lien and Obligation of Assessments Landscaping .....	45
C. – Purpose Assessments .....	45
D. – Annual Assessments .....	46
E. – Special Assessments .....	46
F. – Notice and Quorum for Action .....	47
G. – Rate of Annual Assessment .....	47
H. – Due Dates of Annual Assessments .....	49
I. – Effect of Non-Payment, Non-Compliance; and Remedies Landscaping .....	49
J. – Self-Help Remedies .....	50
K. – Subordination of Assessment Liens to First Mortgage .....	51
SECTION 5: HOLD HARMLESS AGREEMENT .....	51
A. – Indemnities .....	51
B. – Insurance .....	52



# Hardin Business Park

## Amended and Restated Design Standards and Restrictive Covenants

---

SECTION 6: STRUCTURE OF THE OWNERS' ASSOCIATION.....	53
A. – Board.....	53
B. – Membership.....	54
C. – Classes of Membership .....	54
D. – Voting Right of Owners.....	55
E. – Voting Rights of Members.....	55
F. – General Duties and Powers of Association .....	56
SECTION 7: LOT RECONFIGURATION.....	56
SECTION 8: EXHIBITS AND AMENDMENT PROCESS .....	56
A. - Duration .....	57
B. - Amendment .....	57



Page: 4 OF 72

201412190033884

# **Design Standards and Restrictive Covenants**

## **HOW TO USE THESE COVENANTS**

### **STEP ONE – CHOOSING HARDIN BUSINESS PARK**

Review Section 1 of the Development Standards in its entirety to get a complete picture of the requirements. Will your proposed facility fit the plan for Hardin Business Park? If so, then go to Step Two.

### **STEP TWO – SITE SELECTION AND DESIGN**

Which site at Hardin Business Park best fits your needs? Once you have chosen and purchased a site, your architects or engineers will review Section 2. This section will outline what information the Design Review Board requires to review your plans. At this time, our staff recommends a preliminary meeting with your design team to review the standards and make sure they completely understand what is expected. Have your architect or engineer review with you Section 3 and make sure that the plans are in compliance with the Standards. Follow the directions in Section 2 closely and have all materials prepared for review.

### **STEP THREE – REVIEW**

Deliver six (6) sets of plans to The Development Corporation's offices. A Review Board meeting will be planned within ten (10) working days after receipt of these plans. A meeting will not be scheduled until all appropriate information is available to the Board. At the meeting, you will present your facility to the Board. Next, the Board will discuss your plans and you will receive, via written correspondence, notification of the Board's decision and recommendations on changes the Board may require.



## **Hardin Business Park**

### **Amended and Restated Design Standards and Restrictive Covenants**

---

#### **STEP FOUR – PERMIT RELEASE**

Permits can be released through the normal permit application process and the codes department will contact the Corporation for approval.

#### **DECLARATION OF DESIGN STANDARDS AND RESTRICTIVE COVENANTS**

This Amended and Restated Hardin Business Park Design Standards and Restrictive Covenants amends and restates that certain Hardin Business Park Design Standards and Restrictive Covenants dated October 15, 2013, of record bearing Instrument No. 201310290027429 in the Knox County Register of Deeds and is hereby declared as of October 9, 2014, by THE DEVELOPMENT CORPORATION OF KNOX COUNTY, a Tennessee corporation (“Declarant” or “TDC”), so that the covenants, conditions, restrictions, easements, reservations, equitable servitudes and other provisions stated in this Declaration shall run with the land and shall be binding upon the real property in Knox County, Tennessee described in Exhibit “A” (hereinafter referred to as the “Park Property”), and shall be binding upon and inure to the benefit of all parties having any right, title, or interest in such real property and parcels and their heirs, personal and legal representatives, successors and assigns. Declarant hereby declares that all of such real property and parcels shall hereafter be held, sold, conveyed, encumbered, leased, rented, occupied and improved subject to the provisions of this Declaration.

The Association, the Architectural Control Committee, the Declarant, or any Owner shall have the right to enforce, by any proceeding at law or in equity, all restrictions, conditions, covenants, reservations, easements, liens and charges now or hereafter imposed by the provisions of this Declaration. Failure by the Association, the Architectural Control Committee, the Declarant or by any



# **Hardin Business Park**

## **Amended and Restated Design Standards and Restrictive Covenants**

---

Owner to enforce any covenant or restriction herein contained shall in no event be deemed a waiver of the right to do so thereafter. The rights of the Declarant to enforce the provisions of this Declarant shall survive even after the Declarant no longer owns any Lot.

This Declaration shall not be construed to supersede any zoning or subdivision regulation now or hereafter set forth by Knox County, Tennessee.

### **SECTION 1: INTRODUCTION**

#### **A. – PURPOSE OF THESE STANDARDS**

Hardin Business Park is being built by The Development Corporation of Knox County (TDC) to provide a venue for light industrial development in Knox County. A clean, corporate image is envisioned that compliments the nearby neighborhoods and commercial developments. The Development Corporation expects that the availability of light industrial zoned land with appropriate infrastructure will stimulate development that offers employment options while increasing the tax base.

The primary purpose of these standards is to ensure quality development, thus maintaining and enhancing property values in and around the Business Park throughout the life of the development. These Design Standards document the criteria to be used to evaluate and guide each proposed development. Incompatible facilities or activities will not be allowed.

The secondary purpose of these standards is to ensure the continued safe and feasible use of each property. In addition to maintenance and operating standards, only those uses listed in the zoning code of Knox County for commercial or light industrial zones will be considered.

# **Hardin Business Park**

## **Amended and Restated Design Standards and Restrictive Covenants**

---

Finally, Hardin Business Park has been developed by TDC to stimulate the economic development of Knox County. TDC and its assigns shall endeavor to prevent speculation in this development in order to maintain the community's inventory of developed industrial and business properties. It is for this reason that land purchasers must present a plan to TDC Design Review Board for review and approval.

### **B. – PERMITTED USES**

These include clean, light industrial activities that are compatible with the activities and other uses permitted in the Business Park. Businesses specifically permitted include any activity or process that is compatible with the overall objectives of the Business Park. Compatibility will be assessed and reviewed in terms of:

- Truck and automobile traffic generated;
- Proposed storage of raw materials and manufactured products;
- Potential for excessive noise, odors, vibrations;
- Potential for safety hazards to neighboring land uses;
- Capability of pre-treatment, treatment, and/or disposal of domestic and industrial wastes;
- Aesthetic compatibility with Business Park objectives and existing development;
- Size and scale;
- Other criteria that may be established by TDC.

### **C. – SPECIFIC USES NOT PERMITTED**



## **Hardin Business Park**

### **Amended and Restated Design Standards and Restrictive Covenants**

---

As a general guide, the uses permitted under Knox County's Light Industrial zone will be acceptable in the Business Park with the following exceptions being specifically prohibited:

- Churches, schools, libraries, and museums.
- Demolition landfills
- Yard sales and rummage sales
- Self-service storage facilities
- Commercial mulching operations or composting facilities
- Storage of school buses, heavy equipment, etc.
- Sanitary landfills.
- Residences
- Contractor Storage Yard
- Daycares, retail sales, commercial recreation and other similar businesses, except on lots that front Hardin Valley Road

#### **D. – SUBMITTAL REQUIREMENTS**

During the design process, it is recommended that ongoing discussions take place between the purchaser and TDC to ensure that the proposed facility meets the requirements of the Design Review Board. Prior to beginning construction, the following documentation must be prepared by professionals licensed by the State of Tennessee in the appropriate fields and submitted to the Design Review Board for approval. These documents include:



## **Hardin Business Park**

### **Amended and Restated Design Standards and Restrictive Covenants**

---

**The development proposal:** it shall include a brief description of the proposed operation including a facility description with phasing of implementation, traffic generation, number of employees and visitors, noise, odor, vibration or effluent generation, employee shifts, and known hazards or any other unique factors.

**Architectural plans,** including floor plans, elevations, roof plans, building sections, and exterior details. Color samples will be required. Samples of any materials may be requested by TDC or the Design Review Board.

**The site engineering package,** illustrating all improvements including building and pavement layout, design of grading and drainage, vehicular and pedestrian circulation including loading/unloading facilities, utilities, lighting, screen walls, setbacks, construction phase erosion control measures, calculations of Imperious Area Ratio, etc.

**Landscape plans,** including trees, shrubs, and ground covers, slope protection measures, as well as tree preservation and removal.

**Exterior lighting plans** with descriptive and performance data on all fixtures.

**A signage plan** with illustrations of each type of sign.

#### **E. – DEFINITIONS**

(1) “**Assessment**” shall mean a share of the funds required for the payment of expenses and charges which from time to time may be levied against each Owner for the payment of Common Expenses.



## **Hardin Business Park**

### Amended and Restated Design Standards and Restrictive Covenants

---

(2) **“Association”** shall mean and refer to the HARDIN BUSINESS PARK OWNERS’ ASSOCIATION, INC., a Tennessee nonprofit corporation, and its successors and assigns which will be organized under a Charter that will be adopted prior to the first sale of a Lot and incorporated herein by reference and attached hereto as Exhibit B.

(3) **“Board of Directors”** shall mean the board of directors of the Association.

(4) **“Board” or “Design Review Board”** means the Design Review Board which shall be selected pursuant to Section 2A.

(5) **“Bylaws”** shall mean the Bylaws of the Association which will be adopted prior to the first sale of a Lot and incorporated herein by reference and attached hereto as Exhibit C.

(6) **“Common Area”** shall be all real property (including the improvements thereto) located outside the boundaries of the Lots including roadways that are not public streets and will include the entrance to the Hardin Business Park at Hardin Valley Road.

(7) **“Commercial Parcels”** shall mean the following:

Parcels with frontage on Hardin Valley Road, and only that portion of those parcels that are oriented toward Hardin Valley Road.

(8) **“Common Expenses”** shall mean the following:

- (a) expenses of administration of the Association;



## Hardin Business Park

### Amended and Restated Design Standards and Restrictive Covenants

---

- (b) expenses of the maintenance, operation, repair, or replacement of improvements upon the Common Areas;
- (c) all sums lawfully assessed against the Common Area by the Association Bylaws;
- (d) expenses declared Common Expenses by provisions of this Declaration or by TDC or the Association; and
- (e) expenses provided for in any management agreement adopted for the operation of the Common Area.

(9) **“Easements”** shall mean all drainage, sewage, ingress and egress, and utility easements, whether now or hereafter of record, upon or across the Park Property, or as shown on the Plats.

(10) **“Lot”** shall mean and refer to any numbered plot of land shown upon the Plats, as they may be amended from time to time, which is not included within the description of the Common Area.

(11) **“Member”** shall mean and refer to every person or entity who is a record Owner of a fee or undivided free interest in any Lot which is subject by covenants of record to assessment by the Association.

(12) **“Member in Good Standing”** shall mean and refer to a Member not in default in the payment of Assessments.

(13) **“Mortgagee”** shall mean and refer to any record owner, whether one or more persons or entities, of a fee simple title to any Lot which is a part of the Park Property, including contract sellers, but excluding those having such interest merely as security for the performance of an obligation.

## **Hardin Business Park**

### **Amended and Restated Design Standards and Restrictive Covenants**

---

(14) “**Plats**” shall mean and refer to the Plat entitled “Hardin Business Park” dated January 31 2008, of record as Instrument No. 200801310057448 in the Knox County Register’s Office, as amended by re-plats and subdivisions of the Park Property and the Lots from time to time.

(15) “**Park Property**” shall mean and refer to the property described on the Plats.

#### **F. – RE-PURCHASE PROVISIONS**

TDC will sell Lots based on certain assumptions and expectations concerning the economic impact of an Owner’s planned development of its Lot. If an Owner purchases a Lot from TDC but does not commence construction of building improvements, as evidenced by the excavation and commencement of installation of foundations, pursuant to plans approved by the Design Review Board within two (2) years after the sale of such Lot, TDC or its designee shall have the right to repurchase such lot on thirty (30) days notice to the Owner for a sum equal to ninety percent (90%) the purchase price paid by such Owner. Such Owner shall convey the Lot to the TDC or it designee by special warranty deed, subject only to encumbrances approved by TDC and the Owner shall pay any transfer tax and recording cost relating to such conveyance .

## **SECTION 2: DESIGN AND PLAN SUBMISSION - REVIEW PROCESS**

#### **A. – DESIGN REVIEW BOARD**

TDC shall establish the Design Review Board, which shall consist of no fewer than three (3) and no more than six (6) members. The initial members will



## **Hardin Business Park**

### **Amended and Restated Design Standards and Restrictive Covenants**

---

include the president of TDC or a designee, a licensed Architect, a registered Landscape Architect, and a licensed professional Engineer, all of whom live within Knox County. TDC may also designate a professional in the construction business or a real estate developer. Once the Park is 50% occupied, an additional board member may be chosen from an operating business in the Business Park.

Each member of the Board shall serve at the pleasure of the entity appointing them, and each such member can be removed at any time, with or without cause, by the entity that so appointed him. Once 100% of the Business Park's total acreage is sold by TDC or its successor in interest and has been developed by a third party, then the Design Review Board shall be elected by the Owners of the Business Park.

The vote of a majority of the members of the Board at a meeting shall constitute the action of the Board on any matter before it; provided, however, in no event shall a vote of less than three (3) members (either affirmative or negative and not both) constitute the act of the Board. Each Design Review Board member has the responsibility, upon recognizing the potential for the appearance of a conflict or the existence of a real conflict of interest between the member's position and the issue being decided, to declare that he has a conflict of interest on the matter of question. Any member who declares a conflict of interest may continue his involvement in the discussion of the issue but shall excuse himself from voting on the matter.

Approval of plans and improvements shall be at the sole discretion of the Design Review Board. By purchasing property in the Business Park, each



## **Hardin Business Park**

### **Amended and Restated Design Standards and Restrictive Covenants**

---

Owner accepts the authority of these standards and agrees to the Design Review Board's authority.

The rationale for Board approval, conditions or denial shall be included in the minutes of the Board meeting at which decisions are made. Correspondence regarding denials to applicants shall cite the specific section of the Design Standards and Restrictive Covenants for the Business Park or other basis for denial.

#### **B. – REQUIREMENTS FOR THE GRANTING OF A WAIVER OR SPECIAL EXCEPTION**

The Design Review Board may issue waivers of the standards set forth in this document in its sole discretion. However, if an applicant cannot fully satisfy the conditions required by the Board, he or she may appeal to the Property and Construction Committee of TDC for the issuance of a special exception. The Property and Construction Committee of TDC acts as an appellate body for the granting of special exceptions and is not associated with the Design Review Process in any other way. During an appeal for a special exception, the Design Review Board will give its recommendations, in support or denial, to the Property and Construction Committee to facilitate their decision.

An applicant who wishes to appeal for a waiver or special exception has the burden of showing:

- That the granting of the waiver or special exception will not be contrary to the Design Standards set for businesses within the Business Park.
- That the literal enforcement of the Design Standards will result in unnecessary hardship.

## **Hardin Business Park**

### **Amended and Restated Design Standards and Restrictive Covenants**

---

- That by granting the waiver or special exception contrary to the provisions of the Design Standards, the spirit of the Design Standards will be observed.
- That by granting the waiver or special exception, substantial justice will be done.

#### **C. – APPROVAL OF PLANS**

##### **(1) General**

No exterior improvements of any kind shall be erected, altered, placed, assembled, or permitted to remain on a parcel until plans prepared by an architect and/or engineer licensed to practice in the State of Tennessee have been approved by Knox County and the Design Review Board. Plans for improvements to the parcel's landscaping must be received and reviewed by the Board before such improvements may be installed on the parcel. It is the owner's or tenant's responsibility to ensure Knox County and The Development Corporation is aware of all plans, changes, corrections, etc.

Only plans stamped "Approved" by the Board under the Business Park regulations may be used by the owner's or tenant's contractors. The Board shall either approve or disapprove any plans submitted to it within ten (10) business days from the date on which they are submitted; however, the failure to either approve or disapprove within this period will not constitute approval of said plans. Six (6) copies of the plans must be submitted. One (1) copy stamped "Approved" will be retained by TDC and a second stamped copy shall be returned to the Owner. It is the Owner's responsibility to ensure that the Board be aware of all changes, corrections, and alterations.

##### **(2) Issuance of Building and Related Permits**



# **Hardin Business Park**

## **Amended and Restated Design Standards and Restrictive Covenants**

---

Prior to obtaining the necessary building and related permits for construction, the Owner must obtain a written approval from the Board stating that the uses and plans for the parcel have been approved by the Board. Once this approval is given, no changes to the uses or plans can be made without the Board's written consent.

### **(3) Commencement of Construction**

Once approval is received from the Board and related governmental authorities, the Owner may begin construction. Work on the approved construction should begin within six (6) months of the date of the approval. If construction does not begin within this time period, an extension of time must be granted by the Board, or approval for construction will be automatically revoked.

### **(4) Unapproved Construction or Improvements**

Unapproved construction (or improvements) by the Owner is subject to immediate action by TDC or the Owners' Association. Additionally, any improvements which are part of the approved plan and are not constructed on the site are subject to immediate action by TDC or the Owners' Association. Unapproved improvements will be subject to immediate removal from the parcel at Owner's sole expense.

## **SECTION 3: SITE AND STRUCTURE COVENANTS**

### **SITE DESIGN**

#### **General**

A majority of the Business Park has been graded for development. Large building sites have been provided along with the infrastructure development.



## **Hardin Business Park**

### Amended and Restated Design Standards and Restrictive Covenants

---

TDC anticipates that most, if not all construction, will occur within the area already prepared. If land outside the graded area is to be used, the Design Review Board will need to be presented factual information regarding the impacts on surrounding area as well as Beaver Creek and its watershed. Additional clearing will be permitted only with approval by the Board and all applicable regulating authorities. Also, rigorous erosion control standards must be followed in proximity to Beaver Creek.

All site grading shall be in conformance with the Business Park drainage system and in accordance with the Knox County Ordinance 0-00-11-105 on Stormwater Management or the most recent and Knox County Engineering and Public Works Design Standards, as well as any and all other applicable regulations. Swales and other areas of concentrated drainage must be stabilized to limit sediment flow. Other mitigation steps or additional impact information may be required at the discretion of the Board. In general, swales and other non-paved areas of concentrated drainage shall be rip-rapped, sodded and staked or stabilized by structural methods to control erosion.

Orient buildings, parking, storage, and loading areas to reduce less desirable views, noise, and glare off-site. When this is not feasible because of the operational needs of the individual users, additional steps such as screening, landscaping, etc. to mitigate the negative effects shall be required.

Every effort will be made to present a clean, corporate image throughout the Business Park. TDC and its Design Review Board will endeavor to minimize negative influences. In addition to presentable buildings, these guidelines require concealment of service access, refuse handling, and large exposed equipment.

# Hardin Business Park

## Amended and Restated Design Standards and Restrictive Covenants

---

### Clearing and Grading

Extensive site grading at Business Park should not be necessary. Lot grading should be done in such a way, when possible, to preserve and blend with existing topographic features.

**(a) Cut or fill slopes** shall be no greater than 3:1 without Board approval. Slopes greater than 3:1 must be stabilized to prevent erosion or sloughing of the slope.

**(b) When necessary**, terracing and approved retaining walls shall be utilized. Retaining walls shall be constructed of a material that is compatible with the building and approved by the Board. Exposed retaining walls shall be constructed of fieldstone, brick or other approved compatible material.

**(c) Large land areas** disrupted during construction should not be left bare and exposed during the winter-spring runoff period.

**(d) All slopes** and other grass areas shall be seeded with a 50/50 blend of Rebel and Falcon Fescues at a minimum rate of six to eight pounds per one thousand (1,000) square feet. The use of sod is encouraged.

**(e) All development** on lots bordering Beaver Creek shall be done in a manner that protects the stream. Swales and other areas of concentrated drainage into the creek must be stabilized to prevent sediment discharge into the creek. Fill within the floodway is permitted only as outlined on the recorded subdivision plat.

**(f) All site grading** shall be in conformance with Bus. Park drainage system.

## **Hardin Business Park**

### Amended and Restated Design Standards and Restrictive Covenants

---

**(g) Integrate grading and drainage** features for each parcel with the Business Park's overall storm water management system. Storm water systems shall meet all the Knox County requirements and sewer systems shall meet all the state and local utility requirements. Combined storm water and sanitary sewers shall not be permitted.

#### **Stream Buffer**

Many of the parcels adjoin Beaver Creek, and the utmost care must be taken regarding development in the vicinity of the creek. Site-specific legal requirements regarding cut and fill are detailed on the subdivision plat. In addition to the site specific requirements, the following general guidelines will apply.

**(a) Every effort must be made** to construct all facility elements on portions of the site prepared by TDC. Clearing or grading previously undisturbed areas must be approved by the Board, as well as all appropriate federal, state, and local agencies.

**(b) If clearing is to occur,** a storm water management and pollution prevention plan must be approved by the Tennessee Department of Environment and Conservation (TDEC). The plan must address construction phase erosion prevention as well as long-term stabilization.

**(c) Disturbed areas** must be permanently landscaped with native riparian vegetation.

#### **CIRCULATION**

**General**



## **Hardin Business Park**

### **Amended and Restated Design Standards and Restrictive Covenants**

---

Given the anticipated scale and functions of these developments, vehicular circulation will predominate. Therefore, particular attention must be paid to the needs of the pedestrians. Appropriately scaled sidewalks and landscaping should make this experience as comfortable as driving and parking.

Care should be taken to ensure that parking lots and loading areas do not detract from the appeal of the Business Park. Parking lots and loading areas should adequately service the facility without becoming a visual blight. The impact of future expansions will also be considered and additional parking will be required if expansion warrants. All roads and parking shall be paved to accommodate any anticipated loads. Curbs are not required where storm water is sheet drained into bio-retention facilities or approved natural watercourses.

#### **Pedestrian Improvements**

**(a) Walks that are six (6) to eight (8) feet wide** should be provided through parking areas to building entrances and to any other pedestrian destinations.

**(b) Unpaved areas** at least six (6) feet wide should be left adjacent to the walks for landscaping.

**(c) Appropriate lighting fixtures**, bollards, hand rails, and street furniture should be incorporated into pedestrian areas.

#### **Parking**

**(a) No parking will be permitted** on any street or drive, or any place other than the paved parking spaces. Each Owner and Tenant shall be responsible for the compliance of its employees and visitors.

## Hardin Business Park

### Amended and Restated Design Standards and Restrictive Covenants

(b) **No parking shall be located** closer than twenty-five (25) feet from public rights-of-way, nor closer than ten (10) feet from side property lines, nor twenty-five (25) feet from rear property lines. Please refer to “Special Setback and Buffer Considerations” under Building Setbacks and Lot coverage

for exceptions to these parking setbacks.

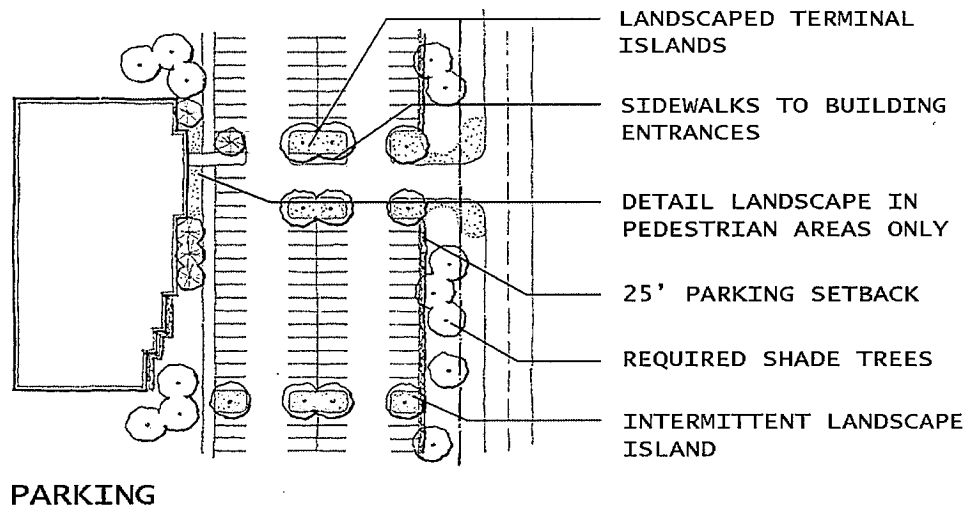

(c) **Parking must be designed** in accordance with acceptable engineering practices provided in the “Institute of Transportation Engineers Parking Design Guide.”

(d) **Landscape islands** that are at least three hundred (300) square feet in area must be incorporated into the parking lot layout. These landscape islands must occur at the terminus of each row of parking.

Also, rows of parking must be interrupted by intermittent landscape islands no less frequently than once in each twenty-five (25) spaces. These islands will

# Hardin Business Park

## Amended and Restated Design Standards and Restrictive Covenants

also be at least three hundred (300) square feet. Large shade trees and ground cover plantings must be installed in each landscape island.

The use of Rain Gardens/Blurentention cells in parking lots is encouraged.

### Loading and Unloading Areas

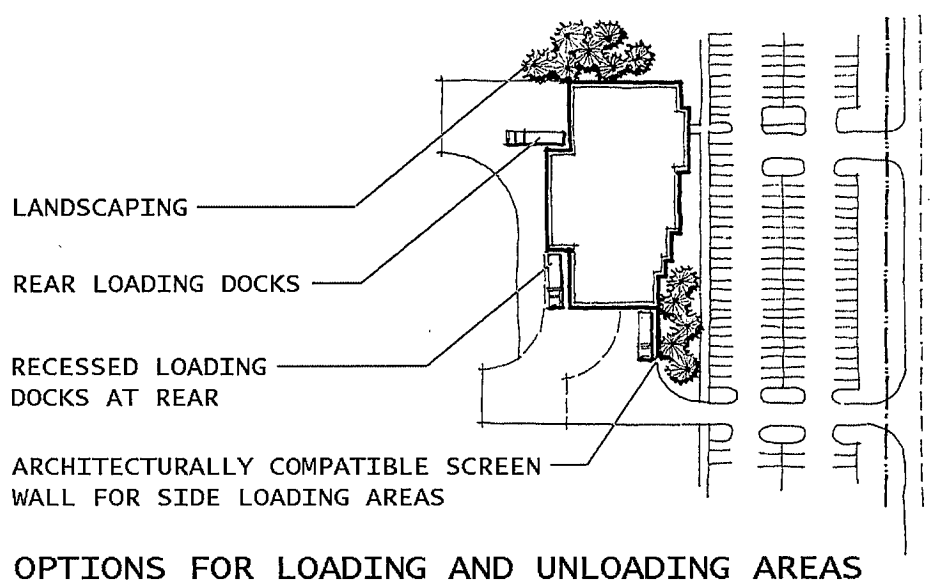

- (a) Loading areas will not infringe in the paving setback areas.
- b) Loading facilities shall be constructed in such a way that when vehicles are loading or unloading, they will not extend past the parcel property line.
- (c) Loading docks will be located at the rear of the building or sides if appropriately screened, unless otherwise approved by the Board in writing.

## **Hardin Business Park**

### **Amended and Restated Design Standards and Restrictive Covenants**

---

Loading docks shall be set back and permanently screened, either by landscaping, berming or architectural screens, from neighboring properties and public view to minimize the effect of their appearance from neighboring building sites.

**(d) Truck loading doors** and utility service areas should be located at the rear or on the sides, toward the rear of buildings so they will not be clearly visible from the street or roadway. In cases where the parcels fronts two (2) streets, these areas should be located on the less prominent street side of the building.

**(e) Vehicle maneuvering** for loading and unloading shall not be permitted on the public streets within Hardin Business Park.

#### **Vehicular Entrances**

Adequate sight distances shall be maintained at site entrances for traffic safety. Turning radii, onto and within parcels, shall be designed to accommodate the largest vehicles anticipated on the respective parcels.

Paving should also be certified to standards sufficient to support anticipated loads on the respective parcels. (Developers should refer to the Industrial Guidelines established by the Knox County Engineering and Public Works Department.) Drive pavement exceeding thirty-six (36) feet in width must be approved by the Design Review Board.

#### **BUILDING SETBACKS AND LOT COVERAGE**

##### **General**





# Hardin Business Park

## Amended and Restated Design Standards and Restrictive Covenants

---

All setback areas for the building sites will follow the guidelines found in the Knox County Zoning Ordinance for the Light Industrial Zone. Any adjustments to these standards must be approved by the Board.

### Building Setbacks / Coverage

#### 1. General Considerations

- (a) **Front setback line** shall be a minimum of seventy-five (75) feet.
- (b) **Side setback line** shall be a minimum of fifty (50) feet.
- (c) **Rear setback line** shall be a minimum of seventy five (75) feet.

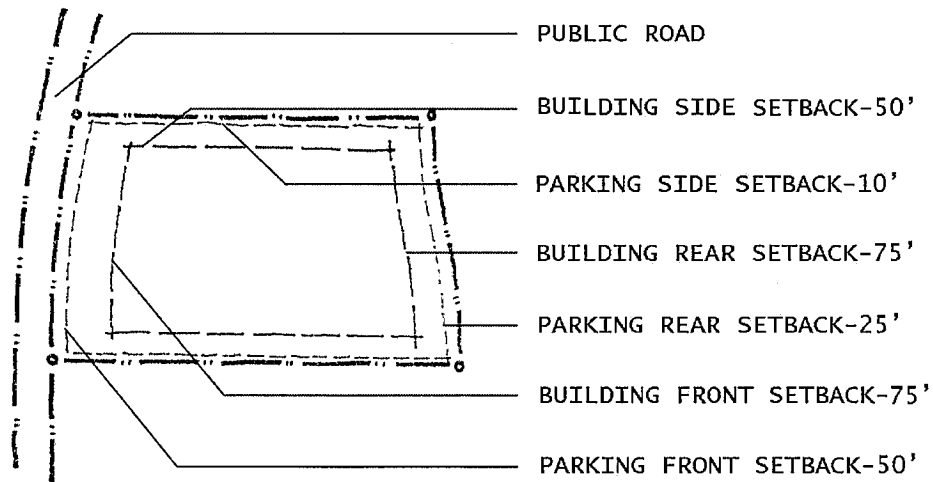

SETBACKS

- (d) **For parcels** that front on more than one roadway or street, the front setback line restrictions shall also apply to the side or rear of the parcel having said frontage.

## **Hardin Business Park**

### **Amended and Restated Design Standards and Restrictive Covenants**

---

(e) **If a single business** uses two (2) or more parcels with a common boundary line, the side setback restrictions at the common boundary line may be waived by the Board.

(f) **Maximum impervious coverage** including buildings and paving shall not exceed 70% of the lot area.

(g) **An unpaved landscape strip** must be provided around the front half of each building. The landscape strip must average at least five (5) feet in width, but in no case should it be less than thirty (30) inches. The landscape strip is required all the way around the front and sides of the building, except where doors enter the buildings.

#### *2. Special Setback & Buffer Considerations*

These Special Setback and Buffer Considerations take priority over the General Considerations for the circumstances listed below.

A one hundred (100) foot building setback and a fifty (50) foot parking setback are required along Reagan Road for all buildings, except for Lot 1. The building and parking setback for Lot 1 shall be fifty (50) foot. A seventy-five (75) foot landscape buffer is required along the north property line of Hardin Business Park, within which no paving or other construction may occur.

ARCHITECTURE



#### **General**

TDC recognizes that the anticipated uses of Hardin Business Park may require large-scale buildings with industrial features. Nonetheless, each building will

## **Hardin Business Park**

### **Amended and Restated Design Standards and Restrictive Covenants**

---

be a clean, well-composed, attractive, facility that meets both the intent and letter of these guidelines. Buildings will be compatible with their surroundings as well as other aspects of the business park.

#### **Building Design**

##### *A. Height*

All building heights shall be subject to pre-construction approval by the Board, and shall conform to the requirements and restrictions of the Knox County Zoning Ordinance.

##### *B. Materials and Colors*

Materials should be used to visually reinforce the design of the building. No building should be veneered entirely with a single material. Each building should use multiple complementary materials. Recommended materials include an exterior of brick, stone, stucco and neutral colored metal. All building elevations shall be faced in a uniform and consistent manner. No buildings with all metal construction will be allowed. These guidelines and standards are not intended to preclude the use of any particular material.

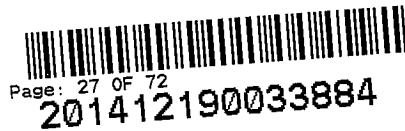

# Hardin Business Park

## Amended and Restated Design Standards and Restrictive Covenants

---

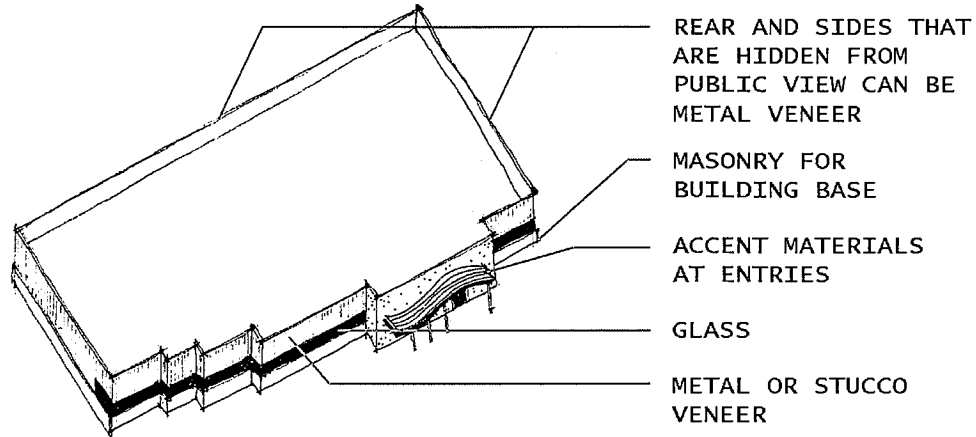

NOTE: A WELL COMPOSED MIX OF MATERIALS IS REQUIRED. THE SPECIFIC MATERIALS SHOWN IN THIS DRAWING ARE NOT REQUIRED.

### OPTIONS FOR BUILDING MATERIALS

Buildings should be faced in medium-value range, earth tones or grays should be dominant. Use of excessively bright primary colors are prohibited except as intermittent accents. Bright accent colors shall not be used on more than ten percent (10%) of any facade.

Any building face that is visible from a public right-of-way shall not be blank. Architectural elements and/or landscaping of a scale which will be effective in breaking up the blank wall shall be used.

#### *C. Entryway*

Differentiate the entry area from the rest of the building face with a change in setback, color, texture, pattern, and/or material.



# Hardin Business Park

## Amended and Restated Design Standards and Restrictive Covenants

---

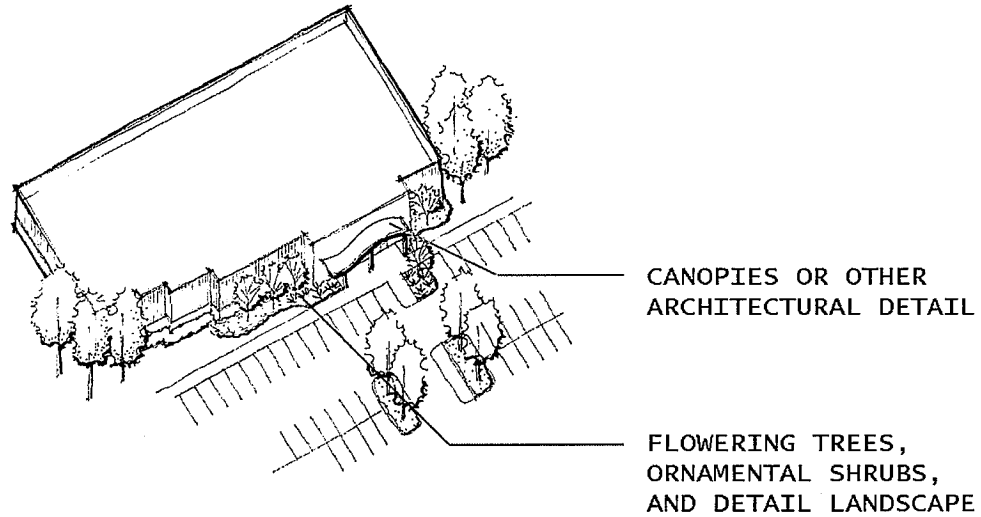

### BUILDING ENTRANCES

#### *D. Accessory Structures*

Multiple building facilities are allowed. All buildings (habitable and uninhabitable) on a parcel must be built of similar construction. These guidelines apply in their entirety to all the buildings, including setbacks. Exterior materials, roofing, landscaping, etc. of accessory structures must match that of the primary buildings.

Service storage areas, loading docks, equipment and garbage and refuse containers, will be concealed and contained within the buildings OR will be concealed and contained by means of a screen wall of material similar to and compatible with that of the building. These elements shall be integrated with the building plan and designed so as not to attract attention. They should be located in the most inconspicuous manner possible. No materials, vehicles, supplies or equipment shall be stored in any area except inside a closed building, unless specifically approved by the Board.

## **Hardin Business Park**

### Amended and Restated Design Standards and Restrictive Covenants

---

#### *E. Service and Storage Areas*

All service and storage areas must be screened with a six (6) foot opaque fence or dense evergreen shrubs which have a mature height of six (6) feet. Appropriate screening shall be approved by the Board.

#### *F. Fencing*

Opaque fencing or walls are required around service areas, exterior utility features, and trash containers that are visible to the public. All fencing materials, locations and heights shall be approved by the Board. Any use of chain-link fences must be approved by the Board and will not be permitted nearer the street than the front facade of the building.

#### *D. Rooftop Structures*

All large rooftop mechanical or process equipment should be screened from public view (to the extent that it is possible) , with parapets or penthouses that are constructed of architecturally compatible materials. Smaller rooftop equipment should be grouped in an orderly manner or in such a way as to minimize its impact on the aesthetic quality of the structure. If a building is proposed to be sited lower than surrounding vantage points, particular care must be taken to appropriately organize or conceal ventilation, process piping, or other visible rooftop equipment.

Utilize low profile rooftop equipment and locate in such a way as to minimize its view from public roads. When equipment cannot be placed out of view, architectural screening will be required.



# Hardin Business Park

Amended and Restated Design Standards and Restrictive Covenants

---

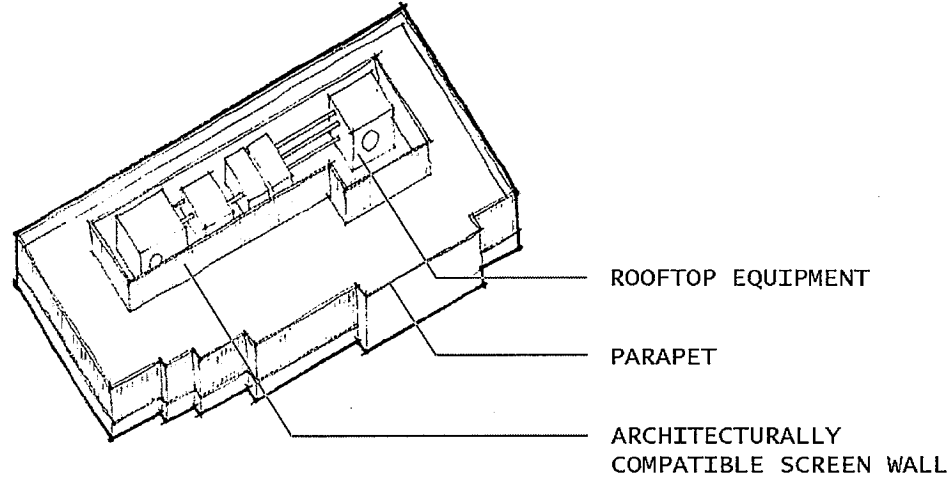

## ROOFTOP STRUCTURES

## LANDSCAPING

### General

These landscaping guidelines are designed to improve the visual quality of the Business Park, provide shade and environmental comfort, establish the pedestrian scale where appropriate, and to provide environmental benefits such as heat island minimization, groundwater deceleration, and erosion control.

All parts of the site not covered by building or pavement must be properly landscaped with living plant material. A minimum general tree planting of eight (8) trees per acre shall be required for each development parcel. These trees are in addition to those required for parking lot islands, or service area screening. At least one half (1/2) of the required number shall be of species capable of attaining a height of fifty (50) feet or more at maturity.

# **Hardin Business Park**

## **Amended and Restated Design Standards and Restrictive Covenants**

---

Along with the project's infrastructure, TDC is installing landscaping at the entrance, along streets and along the visible perimeter of the project. The landscape of each parcel should be coordinated with the development's landscape. No planting should be removed. Plans and specifications for landscaping are subject to approval by the Board.

### **1. Plant Material**

Plant material shall be of the highest grade and quality and shall be installed by a qualified landscape contractor. The minimum acceptable sizes of trees plant materials are:

- Evergreen Trees = 8 feet height
- Flowering Trees = 10 feet height or 2 inch caliper
- Deciduous Trees = 14 feet height or 3 inch caliper
- Evergreen Shrubs = 18 inch minimum height/spread
- Deciduous Shrubs = 24 inch minimum height/spread.

While these guidelines are not intended to be overly prescriptive in terms of species, or design styles, those plants known to be exotic, invasive species are prohibited from use in the Business Park.

### **2. Buildings**

Landscape design should be coordinated with design of the architecture to develop a cohesive image. It is understood that the buildings are likely to be large in scale. Except in pedestrian areas, bold plant massings and strong lines of large hedges will often be more appropriate than detailed, ornamental landscapes. Given the infinite possibilities for development of each parcel, a



# Hardin Business Park

## Amended and Restated Design Standards and Restrictive Covenants

quantity based numeric guideline for the use of plant material is not proposed for the landscape of the building itself. A landscape strip that will be provided per the site design requirements of these Design Standards should include trees, hedges, and ground covers composed in a manner that accentuates the building elements. Each landscape strip must average at least five (5) feet wide, but in no case should it be less than thirty (30) inches.

**Property adjoining public roads or residential properties will require additional landscaping to serve as a screen and buffer.**

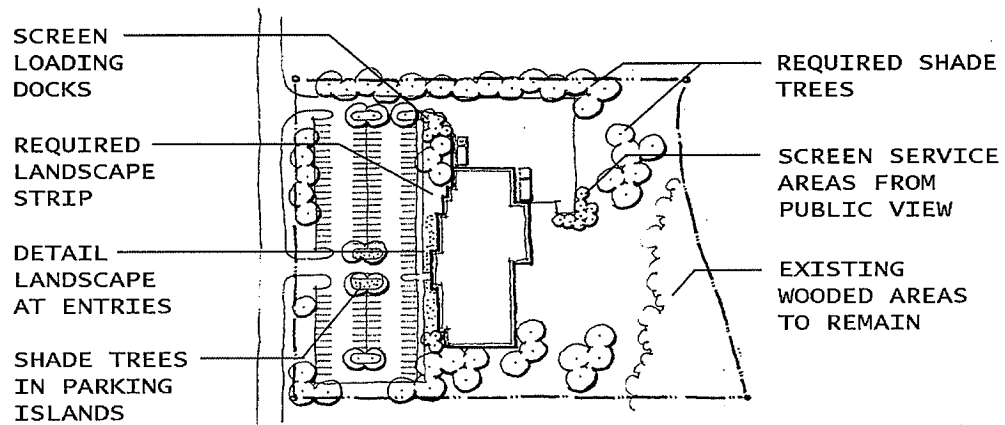

LANDSCAPING

### 3. Parking Areas

(a) **Trees and evergreen shrubs** should be used around the perimeters of parking lots that face public rights of way to screen large areas of pavement.

(b) **In the landscape islands**, at least one (1) large shade tree will be provided along with shrub masses and/or ground plantings other than grass.

# Hardin Business Park

## Amended and Restated Design Standards and Restrictive Covenants

---

(c) **Natural or imposed landforms** such as berms can be used in conjunction with the landscape to screen parking areas.

### 4. Service Areas

In addition to the required fencing, service areas, trash containers, and exterior utility features will be screened from public view through the use of evergreen trees and shrubs. These plant materials will be planted at a density that provides at least fifty percent (50%) opacity. Mature screening should result in greater than eighty percent (80%) opacity.

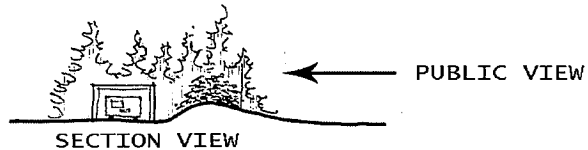
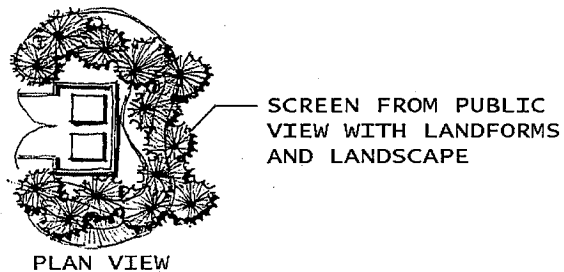

### SERVICES AREAS

### 5. Open Spaces

The large open spaces that result as a requirement of the total lot coverage will be landscaped with lawn and the required shade trees. Evergreen trees, flowering trees, and large shrubs may be included along with berms or other land forms.

# Hardin Business Park

## Amended and Restated Design Standards and Restrictive Covenants

---

### 6. Maintenance/Survival

All landscaping material shall be properly maintained through watering, mulching and fertilizing in such a way as to ensure that plants survive and flourish. Any tree, shrub or ground cover plant which fails to survive shall be replaced with like kind and size within six (6) months of loss. This maintenance is the responsibility of the owner whose parcel this landscaping exists upon. An automatic irrigation system is highly recommended to help with plant performance and minimize mortality.

### LIGHTING

#### General

Light fixtures should be coordinated throughout each parcel and should be appropriately scaled for their placement and use. All lighting shall be designed to keep glare to a minimum, and avoid light leakage onto adjacent properties and streets. All light fixtures should be full-cut-off that totally obscures the bulb from horizontal view. All exterior lighting should be achieved with a metal halide source. Exterior light poles shall have an aluminum/silver color finish.

#### Guidelines

There shall be provided a minimum of 0.5 footcandles maintained on the ground for roadways, and parking lots. Lighting for use areas and entrances shall be five (5) footcandles, and on paths and steps an average of one (1) footcandle. Changes in illumination requirements will be considered when they are consistent with recommendations by the current Institute of Electrical Standards for office and industrial uses.



## **Hardin Business Park**

### **Amended and Restated Design Standards and Restrictive Covenants**

---

(a) **No light shall exceed** thirty (30) feet in height. Recommended range for the height of lights are:

- Roadways and parking areas: twenty (20) to thirty (30) feet
- Intermediate landscape lights and pedestrian lights: ten (10) to fifteen (15) feet
- Pathway lights: less than six (6) feet

(b) **Security lighting** shall be restricted to lighting only loading and storage locations or similar service areas. Lighting shall not project above the fascia or roof line and shall not create glare from the street.

(c) **Accent lighting** and lighting of all pedestrian walkways, loading zones and collector lanes is recommended.

(d) **Surface lighting** must provide good visibility with a minimum of glare. Avoid light spill on adjacent property and fronting streets. Uniform illumination intensity is desirable throughout large areas.

(e) **Landscape lighting** is encouraged, but up-lights are not permitted.

(f) **Building lighting** must use concealed sources of downward illumination, without disturbing neighboring properties and street traffic.

(g) **Colored lights** will not be allowed.

### **POWER, TELEPHONE, UTILITIES, AND WATER/SEWER**



## **Hardin Business Park**

### **Amended and Restated Design Standards and Restrictive Covenants**

---

All electric power lines, water pipes, gas pipes, sewer pipes or drainage pipes (other than rainwater down spouts) shall be installed and maintained below the surface of the ground. All above ground utility structures must be appropriately screened and approved by the Board before construction begins. Meter connections shall be enclosed or screened.

In all utility matters, the requirements of local utility providers shall take precedence unless more stringent requirements are stipulated and no conflict with the utility provider results. All utility easements shall be kept free of all structures unless prior written approval is obtained from the utility district and TDC.

The developer of each parcel shall be solely responsible for determining the presence and location of existing utilities on their respective parcels.

#### **SIGNAGE**

Signs used in Hardin Business Park shall provide clear, logical, and consistent directional information; reinforce an orderly traffic pattern and flow; be legible from moving automobiles; and be located where time is allowed for decisions to be made for appropriate maneuvers. Differences in requirements for the commercial parcels in Hardin Business Park and all other parcels in the Business Park are noted.

The design guidelines shall be used consistently throughout the Business Park to give it a unified appearance. The guidelines specify standards for size, color, form, type style and type size, logo placement, type locations, message content, materials, and general sign locations for each type of sign. Business signs shall be consistent with the sign design guidelines for Hardin Business Park.

# Hardin Business Park

## Amended and Restated Design Standards and Restrictive Covenants

---

### Guidelines:

(a) All sign types shall conform in size and dimension to the Knox County Zoning Ordinance, unless otherwise noted in these TDC Design Standards.

(b) Additional design elements shall conform to the TDC Design Standards, including:

- Finishes should be matte or flat as opposed to glossy or reflective finishes,
- The number of colors on each sign shall be limited to three,
- Materials should be similar to those used on the building, and
- The message on the sign shall be limited to a maximum of corporate name, logo, street address, and parent company, except where otherwise allowed.

(c) Signs can be illuminated either through the use of properly screened ground mounted lights or by Light Emitting Diode (LED) technology. Internally illuminated signs shall not be mounted on a building wall that faces a property line that abuts residentially zoned property. The signs shall be designed so that when illuminated at night, only the letters and or logos of the sign are visible. This shall be accomplished by one of the following methods:

- Channel letters where the raceways, conduits, and other electrical components are concealed from public view, or
- Cabinet design with an opaque and non-reflective background with translucent letters and logos.
- No light shall emanate through the background, the borders, sides, or any other surface of the sign or its supporting structure.

## Hardin Business Park

### Amended and Restated Design Standards and Restrictive Covenants

---

#### **Free-Standing, Business Identity Signs:**

**(a) Identity signs shall establish the image** of the individual Business Park tenants but also repeat the overall forms, materials, and logos chosen for the Business Park. For Commercial Parcels, corporate colors and designs may be used on the business identity signs, subject to approval by the Design Review Board.

**(b) Locate sign(s) to be visible at the main parcel entry** but no closer than twenty (20) feet to the right-of-way.

#### **(c) Free-standing business identity signs are limited to:**

- One (1) sign per building;
- One (1) square foot of sign for every one (1) linear foot of building frontage up to a maximum of one hundred (100) square feet, including both sides;
- Seven (7) feet above grade; and
- Ground-mounted with a fully enclosed base.

#### **Free-Standing, Multi-Tenant Signs:**

**(a) Use a free-standing multi-tenant sign when** there are multiple buildings on a parcel or multiple tenants in one building. Signs are limited to one (1) per building -- multiple tenants should be listed on one sign. Individual free-standing, business identity signs shall not be permitted on parcels with a multi-tenant sign.

**(b) Locate near the building entry area** and at approximately the same location in relation to the entry areas, throughout the Business Park. Use standard sign housing.



## **Hardin Business Park**

### **Amended and Restated Design Standards and Restrictive Covenants**

---

**(c) Colors and materials shall be consistent** with the overall sign concept for the Business Park and shall be complimentary to the building colors and materials on site.

#### **Building Signs:**

**(a) The sign shall be located** on the building face, where it does not extend above the height of the roof eaves and shall be flush mounted.

**(b) Roof-top signs shall not** be permitted.

**(c) Colors and materials shall be consistent** with the overall sign concept for the Business Park and shall be complimentary to the building colors and other materials on site.

**(d) The area of building signs shall be one (1)** square foot for every one (1) linear foot of building frontage with a maximum size of one hundred (100) square feet. Area shall be measured as the sum of the area of individual letters when individual letters are mounted to the building face. When a material other than the building face is used as the sign background, the outermost dimensions of the background material will be measured for size.

**(e) Electronic Message Centers (EMCs) shall be permitted** in the Business Park only on the Commercial Parcels and are subject to:

- Installation as building signs only,
- LED illumination,





## **Hardin Business Park**

### **Amended and Restated Design Standards and Restrictive Covenants**

---

- Appropriate cabinet and screen design (determined during TDC Design Review Board review),
- Nine (9) second static hold time,
- No special effects (such as scrolling, blinking, or flashing),
- No video content,
- Maximum brightness: Daytime – 3,000 nits; nighttime – 750 nits; at the property line – 0.2 footcandles, and
- Meeting all other design restrictions (number, size, location, area, etc.) imposed by Knox County.

#### **Directional and Regulatory Signs**

**(a) Locate where needed** throughout Hardin Business Park -- specifically at road intersections, at service entrances, and in parking areas.

#### **Temporary Signs**

**(a) One (1) construction sign and one (1) “for sale”/“for lease” sign is permitted** per parcel. Signs shall not exceed thirty-two (32) square feet.

#### **ADDITIONAL STANDARDS**

##### **Commercial Parcels**

These Design Standards apply to the commercial parcels except as outlined below.

In addition to the uses permitted under the Knox County Light Industrial Zone, dining establishments, including those that permit consumption of alcohol on the premises, will be allowed, subject to the requirements of other

## **Hardin Business Park**

### **Amended and Restated Design Standards and Restrictive Covenants**

---

authorities having jurisdiction. This does not supercede any other state or local regulations or ordinances.

#### *Site Design General*

The southwest corner of the Business Park designated for commercial uses has not been cleared or mass graded by the developer. A naturally occurring tributary to Beaver Creek flows through these parcels. Extreme sensitivity must be used when working in the vicinity of the creek and its associated riparian landscape. Any work on these parcels must be coordinated with FEMA, TDEC, Knox County, and any other authority having jurisdiction.

#### *Setbacks*

Parking lot setbacks will be ten (10) feet from all property lines. Building setbacks will conform to the Light Industrial Zone requirements.

#### **Noise**

All activities in the Business Park shall conform to the noise standards published in the Knox County Zoning Ordinance.

#### **Pollutants**

No noxious or offensive trades, services or activities shall be conducted on the premises, nor shall anything be done therein which may be or become an annoyance or nuisance to the owner, occupants or neighbors by reason of unsightliness or excessive emission of fumes, odors, glare, vibration, gases, radiation, dust, liquid, wastes, smoke or noise. In any case, the limit of emission of air pollutants shall be subject to the approval of the Knox County Air Pollution Control Board.

## **Hardin Business Park**

### **Amended and Restated Design Standards and Restrictive Covenants**

---

#### **Site Drainage and Storm Water Retention**

No driveways, walks, parking areas, etc., may be constructed across any drainage ditch, channel or swale without providing adequate culverts or waterway openings for natural drainage. No storm water run-off will be discharged into, or permitted to flow into, the sanitary sewage system. Additionally, no sewage will be discharged into, or permitted to flow into, the storm water system.

Owners are required to comply with all Knox County and the EPA's storm water runoff regulations.

#### **Maintenance**

Each Owner and Occupant of the Business Park shall be responsible for keeping its building site (whether or not improved), buildings, and other improvements in a safe, clean, neat, and orderly condition and shall prevent rubbish from accumulation on its building site or surrounding common areas. Landscaping of a building site shall be maintained (including pruning, weeding, re-mulching, mowing, etc.) and each Owner shall promptly replace any dead plant material according to the approved landscape plans at its expense. Any building on any Lot, which is vacant for any reason, shall be kept locked and the windows shall be glazed in order to prevent entrance by vandals. Paved areas shall be kept reasonably in good repair. Drainage systems shall be kept clean and free of any obstacles.

#### **GRIEVANCES AND CONFLICTS**

Each Owner shall be entitled to file complaints with the Board alleging a violation of any covenant. The procedure for doing so is as follows:

## **Hardin Business Park**

### **Amended and Restated Design Standards and Restrictive Covenants**

---

- (1) A complaint shall be filed in writing** to the Board specifying the nature of the violation including the applicable section of this Declaration.
- (2) The Board shall** or an agent of the Board shall investigate the complaints.
- (3) If the Board or its agent concludes** that the complaint filed has merit, the alleged violator shall be promptly notified in writing of the complaint.
- (4) Upon receipt of the written notice** of the complaint, the alleged violator shall have thirty (30) business days within which to begin, in good faith, to cure the violation or file an appeal.
- (5) If an appeal is filed,** the Board shall hear the appeal within ten (10) business days. If at least three (3) members of the Board uphold the findings of the agent, the Board may take the appropriate action to cure the violation.
- (6) If the alleged violator** does not begin in good faith to cure the violation within the thirty (30) business days provided, the Board may take whatever appropriate action it has at law or in equity to cause the violation to be cured.

In a case where conflicts arise between zoning restriction/regulations and applicable building and inspection codes and regulations, the provisions which require more restrictive standards shall apply.

## **SECTION 4: GRANT OF EASEMENTS; COVENANT FOR MAINTENANCE ASSESSMENTS**

### **A. – GRANT OF EASEMENTS**

## **Hardin Business Park**

### **Amended and Restated Design Standards and Restrictive Covenants**

---

TDC, as grantor, hereby establishes and grants to, and for the benefit of, the Owner of each Lot and to the agents, customers, invitees, licensees, tenants and employees of grantee a nonexclusive easement for the benefit of the owner of each Lot, and their agents, customers, invitees, licensees, tenants and employees, over, through and around and the Common Areas for roadways, walkways, ingress and egress, and the use of facilities installed for the comfort and convenience of customers, invitees, licensees, tenants and employees of all businesses and occupants of the buildings constructed on the Lots.

#### **B. – CREATION OF THE LIEN AND OBLIGATION OF ASSESSMENTS**

Each Owner of any Lot, by acceptance of a deed therefore, whether or not it shall be so expressed in such deed, is deemed to covenant and agree to pay to the Association: (1) annual Assessments or charges; and (2) special Assessments for capital improvements to the Common Area, such Assessments to be established and collected as hereinafter provided. The annual and special Assessments, together with interest, costs, and reasonable attorney's fees, shall be a charge on each Lot and shall be a continuing lien upon the Lot against which each such Assessment is made. Each such Assessment, together with interest, costs, and reasonable attorney's fees, shall also be the personal obligation of the person who or entity which was the Owner of such Lot at the time when the Assessment fell due. The personal obligation for the delinquent Assessments shall not pass to such Owner's successors in title unless expressly assumed by them.

#### **C. – PURPOSE OF ASSESSMENTS**

The Assessments levied by the Association shall be used exclusively to promote the development and maintenance of a quality business park



## **Hardin Business Park**

### **Amended and Restated Design Standards and Restrictive Covenants**

---

environment for the businesses located therein and in particular for the construction and maintenance of improvements upon the Common Area, including but not limited to, the costs of repairs, replacements, labor, equipment, materials, management, and supervision, the employment of attorneys to represent the Association when necessary, and such other needs as may arise.

#### **D. – ANNUAL ASSESSMENTS**

**(i) The maximum annual Assessment** for each fiscal year shall be established by TDC or, until such time as one hundred percent (100%) of the Business Park's total acreage is sold by TDC, and developed by a third party, the Assessment may be increased by TDC or the Board of Directors without approval by the Members by an amount not to exceed ten percent (10%) of the maximum annual Assessment of the previous year.

**(ii) Notwithstanding the provisions** of (i) above, the maximum annual Assessment for each fiscal year may be increased without limit by a vote of three-fourths ( $\frac{3}{4}$ ) of the Members who are voting in person or by proxy, at a meeting duly called for this purpose.

#### **E. – SPECIAL ASSESSMENTS**

**(i) In addition to the annual Assessments** authorized above, TDC or the Association may levy, in any fiscal year, a special Assessment for the purpose of defraying in whole or in part, the costs of any construction, reconstruction, repair, or replacement of capital improvements upon the Common Area, including fixtures and personal property related thereto, provided that any such Assessment shall have the assent of three-fourths ( $\frac{3}{4}$ ) of the votes of



## **Hardin Business Park**

### **Amended and Restated Design Standards and Restrictive Covenants**

---

Members who are voting in person or by proxy at a meeting duly called for this purpose. All special assessments shall be fixed at a pro rata rate, based on acreage, for all Lots and may be collected on a monthly basis.

**(ii) Notwithstanding the provisions** of (i) above, in the event that the Common Area is in need of maintenance, repair, or of a capital improvement replacement, and is caused through the willful or negligent act of an Owner, its employees, guests, visitors, clients, customers, or others involved in the business of the Owner, the cost of such maintenance, replacement or repairs, shall be added to and become a part of the assessment to which such Owner's Lot is subject.

#### **F. – NOTICE AND QUORUM FOR ACTION**

Written notice of any meeting called for the purpose of taking any action authorized under Section 4E shall be sent to all Members not less than fifteen (15) days nor more than sixty (60) days in advance of the meeting. At the first such meeting called, the presence of Members or of proxies entitled to cast sixty percent (60%) of all of the votes shall constitute a quorum. If the required quorum is not present, another meeting may be called subject to the same notice requirement, and the required quorum at the subsequent meeting shall be one-half (1/2) of the required quorum at the preceding meeting. No such subsequent meeting shall be held more than sixty (60) days following the preceding meeting.

#### **G. – RATE OF ANNUAL ASSESSMENT**



## **Hardin Business Park**

### **Amended and Restated Design Standards and Restrictive Covenants**

---

Both annual and special assessments must be fixed at a pro rata rate for all Lots and shall be paid to TDC or the treasurer of the Association by each Owner.

TDC or the Association, at such time as the responsibility for such activities is transferred to the Association, shall invoice each Owner their pro rata share of the actual expenses involved in Business Park management, including, but not limited to, landscape maintenance of all Common Areas, possible snow removal from the street, and all expenses involved therein. Each Owner shall pay annually, its share of those expenses based on the fraction of saleable acreage it owns within the Business Park, exclusive of Floodway Areas as shown on the FEMA D-Firm map. Notices will be sent out at the end of each fiscal year. The total saleable acreage within Hardin Business Park, exclusive of road right-of-way and Floodway Areas, as shown on the FEMA D-Firm map, has been calculated as 86.72 acres. Within one hundred twenty (120) days after the end of a fiscal year, TDC or the Association shall forward to the Owner an invoice statement showing the Owner's actual share of the expenses. Payment will be within thirty (30) days of receipt of the invoice statement.

In the event that cash flow becomes a concern, TDC or the Association, in their sole discretion, have the right to change from invoicing in arrears to invoicing in advance for Business Park management expenses. In such case, each Owner is invoiced their pro-rata share of the anticipated Business Park management expenses based on historical data plus or minus any adjustments for anticipated increases or reductions in work for the coming fiscal year. If at the end of the fiscal year, the actual expenses are less than the amount collected in advance, each Owner will receive a pro-rata share refund. If



## **Hardin Business Park**

### **Amended and Restated Design Standards and Restrictive Covenants**

---

actual expenses exceed the amount of Business Park management fees collected in advance (overage costs), then each Owner will be invoiced (due within thirty (30) days of receipt) their pro-rata share of the overage costs. If TDC or the Association decide to start invoicing for Business Park management expenses in advance, invoices will be sent out ninety (90) to sixty (60) days prior to the beginning of the next fiscal year. Payments will be due within thirty (30) days of receipt of the invoice statement.

Matters concerning Park maintenance and common areas will be decided by TDC alone until one hundred percent (100%) of the Business Park's total acreage is sold and developed by a third party. Once this point has been reached, each Member will have one vote per Lot to use in decisions which affect common area maintenance and other park-wide fees which may be desired by Owners or TDC.

#### **H. – DUE DATES OF ANNUAL ASSESSMENTS**

Within one hundred twenty (120) days after the expiration of a fiscal year, TDC or the Board of Directors shall fix the amount of annual Assessment against each Lot. Written notice of the annual Assessment shall be sent to every Owner subject thereto. The due date shall be thirty (30) days of receipt.

TDC or the Association shall, upon demand, and for a reasonable charge, furnish a certificate signed by an officer of TDC or an officer of the Association setting forth whether the Assessments on a specified Lot have been paid.

#### **I. – EFFECT OF NON-PAYMENT, NON-COMPLIANCE; AND REMEDIES**

## **Hardin Business Park**

### **Amended and Restated Design Standards and Restrictive Covenants**

---

Remedies of TDC or the Association for Non-payment of Assessments or Non-Compliance with the Design Standards and Restrictive Covenants.

Any Assessment not paid within thirty (30) days after the due date shall bear interest from the due date at the rate of ten percent (10%) per annum. TDC or the Board of Directors may suspend the voting rights of an Owner and the right of use of the Common Area by an Owner, the Owner's employees, visitors, guests, clients, customers, or others involved in the business of the Owner, for any period of time during which such Owner is in default in the payment of any Assessment. No Owner may waive or otherwise escape liability for the Assessments provided for herein by non-use of the Common Area or abandonment of its Lot.

#### **J. – SELF-HELP REMEDIES**

If any party to this agreement shall default in the performance of any of its obligations hereunder, then the Association or TDC shall, in addition to all other remedies it may have at law or in equity, after thirty (30) days prior written notice to the other party and to any holder of a first mortgage on its Lot, or such lesser period of time as shall be reasonable under the circumstances involved if such failure to perform causes interference with the improvement, operation, or use of the Park Property (except that no notice shall be required in the event of an emergency), have the right to perform such obligation on behalf of such defaulting party and the defaulting party shall reimburse the Association or TDC within thirty (30) days after demand by the Association or TDC for the reasonable costs thereof or for the defaulting party's proportionate share thereof (if the Association or TDC is responsible hereunder for a portion of such costs), together with any interest thereon from the date of demand for such reimbursement plus reasonable collection fees of

## **Hardin Business Park**

### **Amended and Restated Design Standards and Restrictive Covenants**

---

such reimbursement if not paid within said thirty (30) days and collection is required. Any such claim for reimbursement, together with interest as aforesaid, shall be secured by a lien therefore and shall attach to the Lot, and improvements thereon, owned by the defaulting party effective upon recording of any notice thereof in the Knox County Register's Office. Any such lien shall be subordinate to the lien of any first mortgage on the Lot.

#### **K. – SUBORDINATION OF ASSESSMENT LIENS TO FIRST MORTGAGE**

The Assessment liens provided for herein shall be subordinate to the lien of any first mortgage. Sale or transfer of any Lot shall not affect the assessment lien; however, the sale or transfer of any Lot which is subject to any first mortgage, pursuant to a foreclosure thereof or any proceeding in lieu of foreclosure thereof, shall extinguish the lien of such Assessments as to the payment thereof which became due prior to such sale or transfer. No sale or transfer shall relieve such Lot from liability for any Assessments thereafter becoming due or from the lien thereof.

### **SECTION 5: HOLD HARMLESS AGREEMENT**

#### **A. – INDEMNITIES**

Each Owner agrees that it shall be liable for all damages and injuries to any person or property resulting from the use or misuse of the Common Area by its employees, agents or representatives. In the event of any failure to use the Common Area in a safe and reasonable manner due to the acts or omissions of the Owner or the Owner's employees, agents or representatives, the Owner agrees to and shall indemnify and hold harmless TDC, the Association, Knox County, their Board of Directors, employees, and assigns and the other Owners from any liability, claims or expenses (including court costs and

## **Hardin Business Park**

### **Amended and Restated Design Standards and Restrictive Covenants**

---

reasonable attorney's fees and mechanics and materialmen's liens) resulting therefrom.

In addition, each Owner agrees to defend, protect, indemnify and hold harmless each other Owner from and against all claims or demands, including any action or proceedings brought thereon, and all costs, losses, expenses and liability of any kind relating thereto, including reasonable attorney's fees and cost of suit, arising out of or resulting from the injury to or death of any person, or damage to the property of any person located on the Lot owned by each indemnifying Owner; provided, however, the foregoing obligation shall not apply to claims or demands based on the negligence or willful act or omission of such other Owner, its licensees, concessionaires, agents, servants, or employees, or the agents, servants, or employees of any licensee or concessionaire thereof. In the event it is determined that such other Owner was not at fault, then the indemnifying Owner shall reimburse such other Owner for all reasonable costs and/or expenses incurred by it defending against such claim or demand.

#### **B. – INSURANCE**

Each Owner shall maintain or cause to be maintained in full force and effect comprehensive insurance with a financially responsible insurance company or companies licensed to do business in the State of Tennessee insuring against claims on account of loss of life, bodily injury, or property damage that may arise from or be occasioned by, the condition, use or occupancy of such Owner's Lot or the improvements located thereon; and such insurance shall provide for (i) a limit of not less than Two Million Dollars (\$2,000,000.00) for personal or bodily injury or death to any one person, a limit of not less than Five Million Dollars (\$5,000,000.00) for personal or bodily injury or death to

## **Hardin Business Park**

### **Amended and Restated Design Standards and Restrictive Covenants**

---

any number of persons arising out of any one occurrence, and a limit of not less than One Million Dollars (\$1,000,000.00) in respect of any instance of property damage; (ii) worker's compensation insurance as required by any applicable law or regulation; (iii) employer's liability insurance in the amount of One Million Dollars (\$1,000,000.00) each accident for bodily injury, One Million Dollars (\$1,000,000.00) each employee for bodily injury by disease; and (iv) automobile liability insurance for owned, hired and non-owned automobiles. The limits of liability shall not be less than One Million Dollars (\$1,000,000.00) combined single limit each accident for bodily injury and property damage. Such insurance shall extend to the contractual obligation of the insured party arising out of the indemnification obligations set forth in this Declaration.

## **SECTION 6: STRUCTURE OF THE OWNERS' ASSOCIATION**

### **A. – BOARD**

The affairs of the Association shall be managed by a board of directors, which shall consist of no fewer than three (3) nor more than seven (7) directors. Notwithstanding any provision of this Declaration to the contrary, until the Turnover Date (as defined in Section 6C), the number of directors shall be between three (3) and seven (7) and The Development Corporation of Knox County (TDC) shall have the right to appoint all such directors. Subject to the foregoing, the number, term, election and qualification of the Association's Board of Directors shall be fixed in the Association Charter or the Bylaws or both. By resolution, the Board of Directors of the Association may delegate portions of its authority to an executive committee or to other committees, tribunals, officers of the Association or to agents and employees of the Association, but such delegation of authority shall not relieve the Board of

## **Hardin Business Park**

### **Amended and Restated Design Standards and Restrictive Covenants**

---

Directors of the Association of the ultimate responsibility for management of the affairs of the Association. Action by or on behalf of the Association may be taken by its Board of Directors or any duly authorized executive committee, officer, agent or employee without a vote of delegates, except as otherwise specifically provided in this Declaration. In the absence of any subsequent action to the contrary, The Development Corporation of Knox County's Executive Committee and its President shall serve as the Board of Directors for Hardin Business Park.

#### **B. – MEMBERSHIP**

Each Owner of a Lot within the Business Park shall be a member of the Association. There shall be one membership in the Association for each Lot within the BusinessPark. The person or persons who constitute the owner of fee simple title to a Lot shall automatically be the holder of the membership in the Association appurtenant to that Lot, and such membership shall automatically pass with the transfer of the fee simple title to the Lot. Membership in the Association shall not be assignable separate and apart from fee simple title to a Lot, except that an owner may assign some or all of such owner's right as an owner to use improvements or otherwise to a tenant or mortgagee, and may arrange for a tenant to perform some or all of such owner's obligations as provided in this Declaration, but no owner shall be permitted to relieve itself of the responsibility for fulfillment of all of the obligations of an owner under this Declaration.

#### **C. – CLASSES OF MEMBERSHIP**

The Association shall have two classes of voting membership: Class A Owners and Class B Owner.

## **Hardin Business Park**

### **Amended and Restated Design Standards and Restrictive Covenants**

---

**Class A Owners** shall include all owners; provided, however, that so long as TDC is a Class B Owner, it shall not be entitled to Class A membership unless TDC owns a Lot on which a building is being or has been constructed, and then TDC shall be entitled to Class A membership *only* as to such Lot.

**The Class B Owner** shall be TDC and the Class B membership shall exist until the earlier of (a) the date on which all Lots have been sold to and developed by third parties; or (b) the date of which the recording of TDC's relinquishment of its rights to elect all members of the Board of Directors of the Association (the "Turnover Date"). Notwithstanding anything herein stated to the contrary, at such time as Class B membership ceases to exist, TDC shall become a Class A owner with respect to the property in the Park it then owns, if any.

#### **D. – VOTING RIGHT OF OWNERS**

Each Class A Owner shall be a member of the Association and shall have the right to vote for the election of members of the Board of Directors after the Turnover Date (as defined in Paragraph 4c). The Class B Owners shall be members of the Association.

#### **E. – VOTING RIGHTS OF MEMBERS**

Each member shall be entitled to cast one (1) vote for each Lot which is owned by a Class A Owner and which is subject to this Declaration, except that so long as the Class B membership exists, the Class B Owner shall be entitled to one more than the aggregate number of votes which all other members are then entitled to cast, and shall elect all members of the Board of Directors of the Association.

# **Hardin Business Park**

## **Amended and Restated Design Standards and Restrictive Covenants**

---

### **F. – GENERAL DUTIES AND POWERS OF ASSOCIATION**

The Association has been formed to further the common interests of the owners of the Lots. The Association, through the Board of Directors or through persons to whom the Board of Directors has delegated any authorized powers of the Board of Directors, shall have the duties and powers hereinafter set forth and, in general, the powers to perform its duties described in this Declaration and, subject to any limitation set forth in this Declaration, the powers to do anything that may be necessary or desirable to further the common interests of the owners of the Lots, to maintain, improve and enhance the Business Park and to improve and enhance the attractiveness, desirability and safety of Hardin Business Park.

### **SECTION 7: LOT RECONFIGURATION**

Notwithstanding anything herein to the contrary, TDC or its successor in interest reserves the unilateral right to establish, reconfigure, re-subdivide and otherwise modify or change the size and number of any Lot or other portion of the Business Park that is owned by TDC or its successor in interest and to record Plats and other documents, including amendments to this Declaration, for so long as TDC or its successor in interest owns any property in the Business Park. No Owner shall have any right to restrict or prohibit TDC's right to establish, reconfigure, re-subdivide or change Lots, nor shall any Owner have any remedy or claim for damages with respect to TDC's or its successor in interest exercise of such rights.

### **SECTION 8: EXHIBITS AND AMENDMENT PROCESS**

DURATION; AMENDMENT



## **Hardin Business Park**

### **Amended and Restated Design Standards and Restrictive Covenants**

---

**A. DURATION.** Unless otherwise canceled or terminated, all of the easements granted in this Declaration shall continue in perpetuity and all other rights and obligations hereof shall automatically terminate and be of no further force and effect after ninety-nine (99) years from the date hereof.

**B. AMENDMENT.** As long as TDC or its affiliate, assignee or successor owns any property in the Business Park, this Declaration (including exhibits) may be modified or cancelled only with the consent of (i) TDC or its successor in interest as developer of the Business Park and (ii) the owners of fee simple title to at least fifty percent (50%) of the Lots (excluding any Lots owned by TDC). Thereafter, any such modifications may be made by the Association.

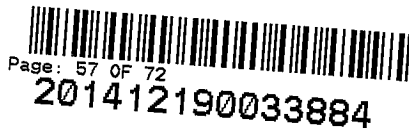

IN WITNESS WHEREOF, the said Party has caused these Amended and Restated Design Standards and Restrictive Covenants of Hardin Business Park to be executed and its name to be signed hereto by its President and Chief Executive Officer.

THE DEVELOPMENT CORPORATION  
OF KNOX COUNTY

By: Todd A. Napier  
Todd A. Napier  
President and Chief Executive Officer

STATE OF TENNESSEE  
COUNTY OF KNOX

Before me, the undersigned authority, a Notary Public of the State and County aforesaid, personally appeared Todd A. Napier, with whom I am personally acquainted, and who, upon oath, acknowledged himself to be the President and Chief Executive Officer of The Development Corporation of Knox County, a non-profit corporation, and that he as such President and Chief Executive Officer, executed the foregoing Amended and Restated Design Standards and Restrictive Covenants of Hardin Business Park for the purposes therein contained, by signing the name of The Development Corporation by himself as President and Chief Executive Officer.

WITNESS my hand and official seal at office in Knox County this 2<sup>nd</sup> day of December, 2014.

Brenda W. Spence  
NOTARY PUBLIC

My Commission Expires:

April 2, 2017

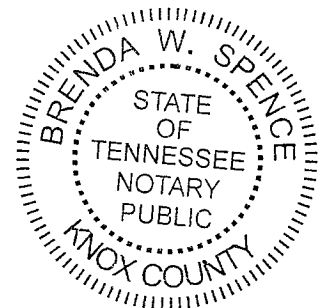

**EXHIBIT "A"**

**Property Description**

**TRACT I**

**SITUATED** in the Sixth (6<sup>th</sup>) Civil District of Knox County, without the corporate limits of the City of Knoxville, Tennessee, being all of **Lot 1, Hardin Business Park, and Bertelkamp Lane**, as shown on plat titled Final Plat of Hardin Business Park, dated January 2, 2008, filed for record as Instrument No. 200801310057448 (consisting of 4 sheets) in the Knox County Register of Deeds Office, to which plat specific reference is hereby made for a more particular description of said lot and Bertelkamp Lane, excepting therefrom Lot 1R, Hardin Business Park, as shown on plat titled Resubdivision of Hardin Business Park Lot 1, dated August 6, 2012, filed for record as Instrument No. 201210020021768 in the Knox County Register of Deeds Office, to which plat specific reference is hereby made for a more particular description of said excepted lot.

**TRACT II**

**SITUATED** in the Sixth (6<sup>th</sup>) Civil District of Knox County, without the corporate limits of the City of Knoxville, Tennessee, being all of **Lot 1R, Hardin Business Park**, as shown on plat titled Resubdivision of Hardin Business Park Lot 1, dated August 6, 2012, filed for record as Instrument No. 201210020021768 in the Knox County Register of Deeds Office, to which plat specific reference is hereby made for a more particular description of said lot.

**FOR SOURCE OF TITLE** see deeds filed for record as Instrument No. 200502150064428, Instrument No. 200502150064430 and Instrument No. 200502150064431, all in the Knox County Register of Deeds Office.



**EXHIBIT "B"**

**Charter**



Page: 60 OF 72

201412190033884

1  
RECORDED IN BOOK 11 PAGE 1516

FILED

**CHARTER  
OF  
HARDIN BUSINESS PARK  
OWNERS' ASSOCIATION, INC.**

Pursuant to Section 48-52-102 of the Tennessee Nonprofit Corporation Act, the undersigned incorporator adopts the following, being qualified so to act:

1. The name of the Corporation is Hardin Business Park Owners' Association, Inc.
2. The Corporation is a mutual benefit corporation.
3. The address of the Corporation's initial registered office, located in Knox County, Tennessee, shall have a physical address of 17 Market Square, # 201, Knoxville, Tennessee 37902, and the Corporation's initial registered agent at that office is Todd Napier.
4. The name of the incorporator is Jennifer M. Swindle, and her address is Long, Ragsdale & Waters, P.C., 1111 Northshore Drive, Suite S-700, Knoxville, Tennessee 37919.
5. The address of the initial principal office of the Corporation shall be 17 Market Square, # 201, Knoxville, Tennessee 37902 (Knox County).
6. The fiscal year of the Corporation shall begin on the first day of July each year, except that the first fiscal year shall begin on the date of incorporation.
7. The Corporation is not for profit.
8. The Corporation shall have two classes of membership, Class A Members and Class B Members. Class A Members shall be owners of lots in the Park Property (as defined in the Declaration) and shall be admitted to membership in accordance with the criteria and procedures established in the bylaws of the Corporation, and no other person or legal entity shall be entitled to Class A Membership; provided, however, that so long as The Development Corporation of Knox County, a Tennessee corporation or permitted assignee (the "Declarant") is a Class B Member then Declarant shall not be deemed a Class A Member unless Declarant owns a Lot(s) on which a building is being or has been constructed (the "Improved Lot") and, in such event, Declarant shall only be entitled to Class A Membership with respect to such Improved Lot(s). Declarant shall be the only Class B Member. Class B Membership shall terminate on the Turnover Date, as defined herein.
9. Upon the dissolution of the Corporation:

Page: 61 OF 72  
201412190033884 VAL

Knox County Page: 1 of 3  
REC'D FOR REC 11/13/2012 3:03:22PM  
RECORD FEE: \$7.00  
M. TAX: \$0.00 T. TAX: \$0.00  
201211130031516

(a) all liabilities and obligations of the Corporation shall be paid and discharged, or adequate provision shall be made therefor;

(b) assets held by the Corporation upon condition requiring return, transfer, or conveyance, which condition occurs by reason of dissolution, shall be returned, transferred, or conveyed in accordance with such requirements; and

(c) all remaining assets of the Corporation shall be transferred to its members in proportion to their ownership interest in the Corporation.

9. The purpose for which the Corporation is organized is to operate and manage the Property for the use and benefit of the owners of lots in the Property, as provided in the Hardin Business Park Design Standards and Restrictive Covenants dated September 28, 2012, (as amended, the "Declaration") by the Declarant of record bearing Instrument No. 201210040022318 in the Register of Deeds for Knox County, Tennessee.

10. The Corporation shall continue to exist as long as the Declaration, as amended, shall be in existence unless sooner dissolved or terminated.

11. No part of the net earnings of the Corporation shall inure to the benefit of, or be distributed to, its directors, officers, or members, except that the Corporation shall be authorized and empowered to pay reasonable compensation for services rendered and to make payments and distributions in furtherance of the purposes set forth hereinabove.

12. The Corporation shall be empowered to operate and manage the Property and other facilities for the use and benefit of the owners of the lots in the Property, as the agent of such owners, as provided in the Declaration.

13. The Corporation shall be authorized to exercise and enjoy all of the powers, rights, and privileges granted to or conferred upon corporations of a similar character by the provisions of TENN. CODE ANN. §48-51-101, et seq., entitled "Tennessee Nonprofit Corporation Act" now or hereafter in force, and to do any and all things necessary to carry out its operations as a natural person might or could do.

14. All of the powers of the Corporation shall be subject to and shall be exercised in accordance with the provisions of the Declaration together with its supporting documents, which govern the use of the Property to be operated and administered by the Corporation.

15. The incorporators, members, and directors of the Corporation shall have the right to take any action required or permitted by vote without a meeting by written consent pursuant to the provisions of TENN. CODE ANN. §48-57-104 and TENN. CODE ANN. §48-58-202.

16. Voting by the members of the Corporation in the affairs of the Corporation shall be on the basis of one (1) vote for each lot owned by such member.



RECEIVED BY THE REGISTER OF DEEDS FOR KNOX COUNTY, TENNESSEE

Notwithstanding the foregoing, until the Turnover Date (as defined herein) the Declarant shall be entitled to a number of votes equal to one more than the number of votes held by all other Members of the Association, as more fully described in the Declaration. The Turnover Date shall be the earlier of (a) the date on which all Lots have been sold to and developed by third parties; or (b) the date on which Declarant relinquishes its rights to elect all members of the Board of Directors of the Association. Each Member shall send notice to the Secretary of the Association of any transfer of a Lot, including the name and contact information for the purchaser.

17. The provisions of this Charter may be amended, altered, or repealed from time to time in accordance with the provisions of the Declaration and the bylaws of the Corporation and in the manner prescribed by the Tennessee Nonprofit Corporation Act, TENN. CODE ANN. §48-51-101, et seq., and any additional provisions so authorized may be added hereto; provided that the provisions of this Charter shall not be changed, modified, repealed, or expanded in such a manner as to be inconsistent with the purposes for which the Corporation is formed.

IN WITNESS WHEREOF, this Charter is adopted as of the 8<sup>th</sup> day of November, 2012.

  
Jennifer M. Swindle

  
Page: 63 OF 72  
201412190033884

  
Page: 3 OF 3  
201211130031516

RECEIVED BY THE SECRETARY OF STATE NOV 11 2012

**EXHIBIT "C"**

**Bylaws**



Page: 64 OF 72

201412190033884



**BYLAWS  
OF  
HARDIN BUSINESS PARK  
OWNERS' ASSOCIATION, INC.**

**ARTICLE I  
NAME AND LOCATION**

**NAME AND LOCATION.** The name of the corporation is **HARDIN BUSINESS PARK OWNERS' ASSOCIATION, INC.**, hereinafter referred to as the "**Association**". The principal office of the corporation shall be located at 17 Market Square, # 201, Knoxville, Tennessee 37902, but meetings of members and directors may be held at such places within the State of Tennessee, County of Knox, as may be designated by the Board of Directors.

**ARTICLE II  
DEFINITIONS**

**Section 1. "Association"** shall mean and refer to Hardin Business Park Owners' Association, Inc. and its successors and assigns.

**Section 2. "Class A Members"** shall be owners of lots in the Park Property (as defined in the Declaration) and shall be admitted to membership in accordance with the criteria and procedures established in the bylaws of the Corporation, and no other person or legal entity shall be entitled to Class A Membership; provided, however, that so long as the Declarant is a Class B Member then Declarant shall not be deemed a Class A Member unless Declarant owns a Lot(s) on which a building is being or has been constructed (the "Improved Lot") and, in such event, Declarant shall only be entitled to Class A Membership with respect to such Improved Lot(s).

**Section 3. "Class B Member"** shall be the Declarant. Class B Membership shall terminate on the Turnover Date.

**Section 4. "Declaration"** shall mean and refer to the Hardin Business Park Design Standards and Restrictive Covenants dated September 28, 2012, recorded or to be recorded in the Office of the Register of Deeds of Knox County, Tennessee, as the same may be properly amended.

**Section 5. "Developer"** shall mean and refer to The Development Corporation of Knox County, a Tennessee corporation, and its successors and assigns.

**Section 6. "Lot"** shall have the meaning given it in the Declaration, as amended.



**Section 7. "Member"** shall mean and refer to those persons entitled to membership in the Association as provided in the Declaration. The Corporation shall have two classes of Members, Class A Members and Class B Members.

**Section 8. "Owner"** shall mean and refer to the record owner, whether one or more persons or entitles, of the fee simple title to any Lot which is a part of the Properties, including contract sellers, but excluding those having such interest merely as security for the performance of any obligation.

**Section 9. "Properties"** shall mean and refer to that certain real property described in the Declaration and such additions (if any) thereto as may hereafter be added to the development.

**Section 10. "Turnover Date"** shall be the earlier of (a) the date on which all Lots have been sold to and developed by third parties; or (b) the date on which Declarant relinquishes its rights to elect all members of the Board of Directors of the Association

**Section 11. "Terms"** Other terms used herein but not defined shall have the meanings given them in the Declaration.

### ARTICLE III MEETING OF MEMBERS

**Section 1. Annual Meetings.** The first annual meeting of the Members shall be held within one year from the date of incorporation of the Association, and each subsequent regular annual meeting of the Members shall be held within the same month of each year thereafter.

**Section 2. Special Meeting.** Special meetings of the Members may be called at any time by the President or by the Board of Directors, or upon written request of Members who are entitled to vote one-fourth (1/4) of all of the votes of the membership.

**Section 3. Notice of Meetings.** Written notice of each meeting of the Members shall be given by, or at the direction of, the secretary or person authorized to call the meeting, by sending a copy of such notice by mail, email or other reliable electronic means at least five (5) calendar days before such meeting to each Member entitled to vote, addressed to the Member's address last appearing on the books of the Association, or supplied by such Member to the Association for the purpose of notice. Such notice shall specify the place, day and hour of the meeting, and, in the case of a special meeting, the purpose of the meeting.

**Section 4. Quorum.** The presence at the meeting of Members entitled to cast, or of proxies entitled to cast, one-tenth (1/10th) of the votes of each class of membership shall constitute a quorum for any action except as otherwise provided in the

Charter, the Declaration, or these Bylaws. If however, such quorum shall not be present or represented at any meeting, the Members entitled to vote shall have power to adjourn the meeting from time to time, without notice other than announcement at the meeting, until a quorum as aforesaid shall be present or be represented.

**Section 5. Proxies.** At all meetings of Members, each Member may vote in person by proxy. All proxies shall be in writing and filed with the secretary. Every proxy shall be revocable and shall automatically cease upon conveyance by the Member of his Lot.

**Section 6. Manner of Acting.** If a quorum is present, the affirmative vote of Members holding voting rights in excess of fifty percent (50%) of all voting rights held by the Members represented at such meeting shall constitute the act of the Members, unless the vote of a greater or lesser proportion or number is otherwise required by these Bylaws. Notwithstanding the foregoing, until the Turnover Date the Class B Member shall hold a number of votes equal to one more than the aggregate of all votes held by Class A Members.

#### ARTICLE IV BOARD OF DIRECTORS: SELECTION; TERM OF OFFICE

**Section 1. Number.** The affairs of this Association shall be managed by a board not less than three (3) nor more than seven (7) directors.

**Section 2. Term of Office.** At each annual meeting the Members shall elect directors for terms one (1) year; provided that if a director is not duly elected at the end of such one (1) year period, such director shall continue to serve until a successor is duly elected.

**Section 3. Removal.** Any director may be removed from the Board, with or without cause, by a majority vote of the Members of the Association holding the right to vote as described in the Declaration. In the event of death, resignation, or removal of a director, his successor shall be selected by the remaining members of the Board and shall serve for the unexpired term of his predecessor.

**Section 4. Compensation.** No director shall receive compensation for any service he may render to the Association. However, any director may be reimbursed for his actual expenses incurred in the performance of his duties.

**Section 5. Action Taken Without a Meeting.** The directors shall have the right to take any action in the absence of a meeting which they could take at a meeting by obtaining the written approval of all the directors. Any action so approved shall have the same effect as though taken at a meeting of the directors.

**Section 6. Manner of Acting.** The act of a majority of the Directors present at any meeting at which a quorum is present shall be the act of the Board of Directors.

**ARTICLE V  
NOMINATION AND ELECTION OF DIRECTORS**

**Section 1. Nomination.** Nomination for election to the Board of Directors shall be made by a Nominating Committee. Nominations may also be made from the floor at the annual meeting. The Nominating Committee shall consist of a Chairman, who shall be a member of the Board of Directors, and two or more Members. The Nominating Committee shall be appointed by the Board of Directors prior to each annual meeting of the Members, to serve from the close of such annual meeting until the close of the next annual meeting, and such appointment shall be announced at each annual meeting. The Nominating Committee shall make as many nominations for election to the Board of Directors as it shall in its discretion determine, but not less than the number of vacancies that are to be filled.

**Section 2. Election.** Election to the Board of Directors shall be by voice vote unless a written ballot is requested. At such election the Members or their proxies may cast, in respect to each vacancy, as many votes as they are entitled to exercise under the provisions of the Declaration. Subject to Section 3 below, as of the date hereof each Lot shall be entitled to one (1) vote. The persons receiving the largest number of votes shall be elected. Cumulative voting is not permitted.

**Section 3. Developer Control.** Notwithstanding anything to the contrary contained herein until the Turnover Date (as defined herein) (i) the Class B Member shall select seven (7) of the members of the Board of Directors, and (ii) the Class B Member shall be entitled to a number of votes equal to one more than the number of votes held by Class A Members until the Turnover Date, as defined herein.

**ARTICLE VI  
MEETINGS OF DIRECTORS**

**Section 1. Regular Meetings.** Regular meetings of the Board of Directors may be held monthly with notice, at such place and hour as may be fixed from time to time by resolution of the Board. Should said meeting fall upon a legal holiday or weekend day, then that meeting shall be held at the same time on the next day which is not a legal holiday.

**Section 2. Special Meetings.** Special meetings of the Board of Directors shall be held when called by the president of the Association, or by any three (3) directors, after not less than three (3) calendar days' notice to each director.

**Section 3. Quorum.** A majority of the number of directors shall constitute a quorum for the transaction of business. Every act or decision done or made by a



majority of the directors present at a duly held meeting at which a quorum is present shall be regarded as the act of the board.

## ARTICLE VII POWERS AND DUTIES OF THE BOARD OF DIRECTORS

**Section 1. Powers.** The Board of Directors shall have power to:

(a) exercise for the Association all powers, duties, and authority vested in or delegated to this Association and not reserved to the membership by other provisions of these Bylaws, the Charter, or the Declaration;

(b) declare the office of a member of the Board of Directors to be vacant in the event such Member shall be absent from three (3) consecutive regular meetings of the Board of Directors;

(c) employ a manager, an independent contractor, or such other employees as they deem necessary, and to prescribe their duties; and

(d) make purchases for the maintenance, repair, replacement, administration, management and operation of the Common Area (as defined in the Declaration), and to delegate any such powers to a managing agent (and any employee or agents of a managing agent).

**Section 2. Duties.** It shall be the duty of the Board of Directors to:

(a) cause to be kept a complete record of all its acts and corporate affairs and to present a statement thereof to the Members at the annual meeting of the Members, or at any special meeting when such statement is requested in writing by one-fourth (1/4) of the Members who are entitled to vote;

(b) have oversight of all officers, agents, and employees of this Association in the performance of their respective duties;

(c) as more fully provided in the Declaration, to:

(1) fix or caused to be fixed the amount of the annual assessment against each Lot, subject to monthly or less frequent billing; and

(2) use reasonable efforts to collect any past due assessments.

(d) issue, or to cause an appropriate officer or other agent to issue, upon demand by any person, a certificate setting forth whether or not any assessment has been paid. A reasonable charge may be made for the issuance of these

certificates. If a certificate states an assessment has been paid, such certificate shall be conclusive evidence of such payment.

## ARTICLE VIII OFFICERS AND THEIR DUTIES

**Section 1. Enumeration of Officers.** The officers of this Association shall be a president, a secretary, and such other officers as the Board may from time to time by resolution create.

**Section 2. Election of Officers.** The election of officers shall take place at the first meeting of the Board of Directors following each annual meeting of the Members.

**Section 3. Term.** The officers of this Association shall be elected annually by the Board, and each shall hold office for one (1) year unless he or she shall sooner resign, or shall be removed, or otherwise be disqualified to serve.

**Section 4. Special Appointments.** The Board may elect such other officers as the affairs of the Association may require, each of whom shall hold office for such period, have such authority, and perform such duties as the Board may, from time to time, determine.

**Section 5. Resignation and Removal.** Any officer may be removed from office with or without cause by the Board. Any officer may resign at any time by giving written notice to the Board, the president, or the secretary. Such resignation shall take effect on the date of receipt of such notice or at any later time specified therein, and unless otherwise specified therein, the acceptance of such resignation shall not be necessary to make it effective.

**Section 6. Vacancies.** A vacancy in any office may be filled by appointment by the Board. The officer appointed to such vacancy shall serve for the remainder of the term of the officer he replaces.

**Section 7. Multiple Offices.** The offices of secretary and treasurer may be held by the same person. No person shall simultaneously hold more than one of any of the other offices except in the case of special offices created pursuant to Section 4 of this Article.

**Section 8. Duties.** The duties of the officers are as follows:

### PRESIDENT



(a) The president shall preside at all meetings of the Board of Directors; shall see that orders and resolutions of the Board are carried out; may sign all written instruments including checks.

## SECRETARY

(b) The secretary shall, or so cause to be, record the votes and keep the minutes of all meetings and proceedings of the Board and of the Members; serve notice of meetings of the Board and of the Members; keep appropriate current records showing the Members of the Association together with their addresses, and shall perform such other duties as required by the Board. If there is no treasurer, the secretary shall, or so cause to be, receive and deposit in appropriate bank accounts all monies of the Association and shall disburse such funds as directed by resolution of the Board of Directors and keep proper books of account.

## ARTICLE IX COMMITTEES

The Board of Directors may appoint committees as deemed appropriate in carrying out its purpose.

## ARTICLE X BOOKS AND RECORDS

The books, records, and papers of the Association shall at all times, during reasonable business hours, be subject to inspection by any Member. The Declaration, the Charter, and the Bylaws of the Association shall be available for inspection by any Member at the principal office of the Association, where copies may be purchased at reasonable cost.

## ARTICLE XI AMENDMENTS

**Section 1.** These Bylaws may be amended, at a regular or special meeting of the Members by a vote of a majority of a quorum of Members present in person or by proxy who are permitted to vote under the terms of these Bylaws and the Declaration.

**Section 2.** In the case of any conflict between the Charter and these Bylaws, the Charter shall control; and in the case of any conflict between the Declaration and these Bylaws, the Declaration shall control.

## ARTICLE XII MISCELLANEOUS



The fiscal year of the Association shall begin on the first day of July and end on the 30 day of June of every year, except that the first fiscal year shall begin on the date of incorporation.

IN WITNESS WHEREOF, the undersigned adopts these Bylaws, as permitted under the Hardin Business Park Design Standards and Restrictive Covenants dated September 28, 2012 by The Development Corporation of Knox County, a Tennessee corporation, recorded or to be recorded in the Office of the Register of Deeds of Knox County, Tennessee.

**THE DEVELOPMENT CORPORATION  
OF KNOX COUNTY**

By: Todd A. Nipier  
Name: Todd A. Nipier  
Title: President



Page: 72 OF 72

201412190033884